

## The Uniqueness of Ho Chi Minh in Political Communication



Nguyen Duy Quynh<sup>1</sup>, Nguyen Thu Trang<sup>2</sup>, Tran Truong Gia Bao<sup>3</sup>

<sup>1</sup>VNU University of Social Sciences and Humanities, No. 336 Nguyen Trai Street, Thanh Xuan district, Hanoi, Vietnam

<sup>2,3</sup>PhD candidate VNU University of Social Sciences and Humanities, No. 336 Nguyen Trai Street, Thanh Xuan district, Hanoi, Vietnam

**ABSTRACT:** Ho Chi Minh was great leader who wholeheartedly devoted himself to the country and the happiness of the people. His lessons and ideas are timeless, as evidenced by the fact that they have been studied continuously by scholars from all over the world. The political communication is just one component of that. Despite the fact that under the presidency of Ho Chi Minh, this concept was most likely still quite vague, the methods that Ho Chi Minh utilized in political communication demonstrated a significant amount of progress. In the following article, we will concentrate on the primary strategies that President Ho Chi Minh utilized in the course of his political communication endeavors. The content of this article is broken up into three sections: the first section introduces some fundamental concepts and rationale; the second part analyzes President Ho Chi Minh's style of political communication; and the third and final section provides some comments and evaluations.

**KEYWORDS:** President Ho Chi Minh, political communication, President Ho Chi Minh's style

### I. SOME CONCEPTS AND THEORETICAL BASIS

There are many definitions of political communication, but none of them appears to be universally accepted in international academia. This is likely due to the fact that it is very difficult to fully and accurately define this concept. The difficulty stems from the fact that itself includes many smaller concepts, and it is not simple to use a specific number of words to describe all of the activities and elements that are related to it. Therefore, in order for us to be able to understand political communication, we need to first begin with the two basic elements which are politics and communication.

The term "communication" can refer to an exceedingly broad range of activities. Some researchers describe it according to the purpose, while others define it according to the means. Because of this, it is quite difficult to find a single description that adequately encompasses all aspects of this concept. But even though definitions can be different in many ways, most of them talk about five basic parts: the transmitter, the receiver, the means, the message, and the effects. To put it simply, communication starts when a transmitter makes up a message. This message is then encoded by turning it into a signal or signal sequence and sending it over a certain medium or channel to the receiver. The receiver then decodes the message, figures out what it means, and sends back a signal, a piece of information that shows whether the message has been understood or not. This is called providing feedback. During the process of sending the message, "interference" could happen, which would make the information less accurate than it was at first. Shannon and Weaver came up with this idea in 1949. (Shannon and Weaver, 1949).

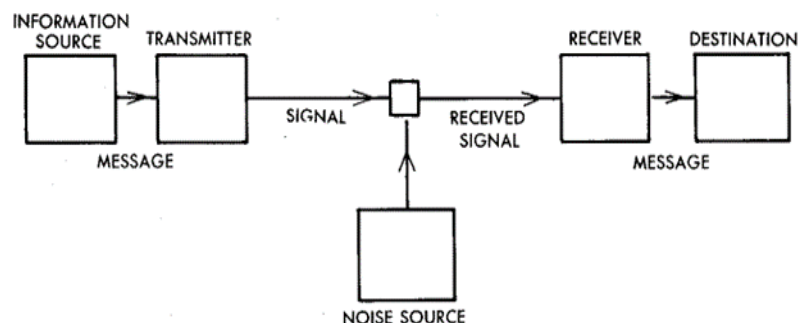

## **The Uniqueness of Ho Chi Minh in Political Communication**

The second concept is politics, which in ancient Greek meant "affairs of states." It has been discussed by many prominent scholars of the past, such as Herodotus, Plato, Aristotle, etc. Today, scholars like Bernard Crick have looked at politics from many different points of view, building on the ideas of their predecessors. Accordingly, he argued, "... politics is a distinctive form of rule whereby people act together through institutionalised procedures to resolve differences, to conciliate diverse interests and values and to make public policies in the pursuit of common interests." (Crick, 2004).

When combining these two components into the concept of political communication, academics have identified a variety of ways. Some definitions are quite specific, while others are quite general, such as Chaffee's. According to him, political communication is the "role of communication in the political process" (Chaffee, 1975). However, other scholars tend to give definitions with more facets. Pippa Norris is one of them. He believed, "Political communication is an interactive process concerning the transmission of information among politicians, the news media, and the public. The process operates top-down from governing institutions toward citizens, horizontally in linkages among political actors, and also bottom-up from public opinion toward authorities" (Norris, 2015). Or according to Brian McNair in "An Introduction to Political Communication," he mentioned that political communication is "purposeful communication about politics." And that "All forms of communication undertaken by politicians and other political actors for the purpose of achieving specific objectives. Communication addressed to these actors by non-politicians such as voters and newspaper columnists. Communication about these actors and their activities, as contained in news reports, editorials, and other forms of media discussion of politics" (McNair, 2011).

So, we can see that all of the above definitions of political communication have something in common: communication activities that allow people to interact and share information in two directions. The top-down direction is from individuals and organizations with political elements to the people, and the bottom-up direction is from the people to the politicians or political agencies and organizations. Both of these effects are ways for each element to reach its specific goals.

These theoretical bases will help to analyze Ho Chi Minh's political communication activities in the following sections.

## **II. PRESIDENT HO CHI MINH WITH POLITICAL COMMUNICATION.**

### **A. President Ho Chi Minh used political communication to make people understand, trust and support.**

When comparing President Ho Chi Minh's political communication activities to the theories of international scholars mentioned above, President Ho Chi Minh's political communication shows many similarities, but it also has some distinct features that come from the uniqueness of his style.

First of all, with the top-down direction, which is specifically the direction from the Party, and from the State to the Vietnamese people, he has his own unique that very effective approaches.

The Mass mobilization work was one way that President Ho Chi Minh got his political communication across. A mass mobilization means "No one should be left out of the effort to do the jobs that need to be done, the jobs that the government and unions have given out. This means that every citizen's efforts should be put to use. The mass media can't just use newspapers, books, meetings, slogans, flyers, and orders. First, it's important to find a way to explain to every citizen: it's for their own good and their duty, and they themselves need to work hard to make it happen" (Hồ Chí Minh toàn tập, ep.6). Therefore, it is possible to see that "Mass Mobilization," from the point of view of President Ho Chi Minh, is to help people comprehend the activities of the Government, about the policies of the State, in order for them to know, understand, and voluntarily implement the policies. Many similarities can be drawn between this definition of political communication and others like it offered by Pippa Norris. As mentioned above, Norris believed, "Political communication is an interactive process concerning the transmission of information among politicians, the news media, and the public" (Norris, 2015). Nevertheless, Ho Chi Minh's perspective in this interaction appears to be more nuanced when he underlines that the ultimate goal is to make people comprehend and get people actively involved in the process.

President Ho Chi Minh always put the question of how to make people understand first in his communicating campaign, because if people understand, they can believe and listen. That is why he always reminds journalists and the media that "our press is not for a few individuals, but to serve the people, to disseminate and explain the Party's and Government's programs and policies. As a result, the press must have a general appeal as well as a combative spirit" (Huy Hung 2021). Writing for newspapers needs to avoid being overly wordy and should cater to the reading level and attention span of the general public. Ho Chi Minh once stated, "My experience is this: Every time you write an article, ask yourself: Who are you writing for? Why do you need to write? How can one write in a way that is easy to understand, concise and easy to read?" (Nguyen, 2020). Better yet, when you have finished writing the article, it should be sent to a few individuals who have a low level of education so that they may read it to check if there is any word that they do not understand, and if there are, it needs to be corrected to make it easier to grasp (Ha, 2021). In addition, one of the most important lessons that Uncle Ho teaches journalists is that the language utilized by the press must be clear, simple, and easy to comprehend and that writing must be concise, which means that it must be neat, and contain content that is specific, penetrating, and

## The Uniqueness of Ho Chi Minh in Political Communication

practical. If a journalist wants to write in a way that is "pure, simple, and easy to comprehend," they must first learn how to speak the language of the masses. Only then can the masses acknowledge what is written as being representative of themselves. Because of this, we can see that President Ho Chi Minh placed a great deal of importance on writing. He chose to write very concisely, but he always made sure to pick the words that were the most appropriate and necessary. This allowed anyone, from someone with a high level of education to a farmer, to comprehend his writing. This has been clear to us the very first works of him. For instance, in the book "Đường Kách Mệnh" (Revolutionary Path), Ho Chi Minh did not provide a definition of "Revolutionary" that was extremely academic; rather, he expressed it in a very short manner by saying, "Revolutionary means to shatter the old into the new, demolish the wrong to change the good." In the same piece of writing, Ho Chi Minh made the following assertion: "This book aspires to be brief, easy to grasp, and easy to remember. Someone may criticize grumpy expressions. Well, all things need to be expressed in a simplistic way with no decoration " (Hồ Chí Minh toàn tập, ep.2). As a result of this, we can see that Uncle Ho's words are always relevant to the general populace. He made an effort to explain everything in a way that readers of any skill level might comprehend it. As a result, the words that Uncle Ho penned down have the potential to touch the minds of a large number of people and be acknowledged by them as their own.

The facts of the present day demonstrate that effective leaders produce superior results by employing language that is simple and straightforward. US President Donald Trump is a good example. Usually, the language used in politics will often have a lot of associations, politicians also often have to be highly educated (Naciscione, 2001) or have a strong political background (Rozina and Karapetjana, 2009). This very easily leads to the conclusion that the listener may have difficulty understanding abstract concepts or that they are required to have the necessary previous knowledge in order to comprehend the information that is being conveyed. As a consequence of this, a great number of people believe that Mr. Trump's ability to communicate in a way that is both clear and succinct was one of the contributing causes to his success in the race for the White House. In the same way, he was able to convince a large number of people to comprehend, believe, and support his views. Many people believe that Donald Trump's manner of speech is distinct from that of typical politicians because he is very succinct and uses words and grammar that are very basic. For instance, he does not use the word "finance" but instead uses the word "money," and he does not use the phrase "causes negative effects" but instead uses the word "bad" (Swaim, 2015). He accomplished this by making his message accessible to the majority of people, which in turn convinced them to back him. After President Trump's speech, which was simple but very effective, people started to pay more attention to using easy-to-understand language to reach the vast majority of people, not just in politics but in other fields as well. A lot of research has been done on this topic. Nevertheless, it is clear that during the time of President Ho Chi Minh, he was aware of this situation fairly early on in his tenure. Because Uncle Ho's speaking and writing style tends to be "simple," "clear," and "easy to understand," the information that he communicates always manages to touch the minds of the people because they understand it, they listen to it, and they follow it.

### B. Political communication to increase trust among people

To make people voluntarily comply, they must first trust the government and their leaders. If we live in the modern world, there are many ways for leaders to gain the trust of the people, such as through the media, social media apps, etc. Politicians can also build their own image and reputation by putting up biographies and keeping people up to date on their daily political or government activities on their own pages or on newspapers. People get news from there very quickly, which makes it easy for the news to spread. People may not see these things happening directly, but images and news picked by the media will help them understand and, over time, grow to like or trust what the government does and who runs it. However, this trust is gradually lost in many situations because the government is either unable to deliver on what it has promised or does provide, but does not bring about the intended impact. In this regard, President Ho Chi Minh is maybe an expressive example of "saying must go hand in hand with action," or stating that it must be done. Uncle Ho has consistently held the belief that one's success in their work should be proportional to the amount of effort one put in. It is even more vital for leaders to walk the walk as well as talk the talk since they set an example for everyone else to look up to and follow. This will also make people trust the government more. He said, "An important example is worth more than hundred speeches." (Hồ Chí Minh toàn tập, ep.1). For Uncle Ho, when proposing work, it is necessary to avoid being vague or confusing and instead be specific, practical, and go from small to big, low to high, and easy to hard. Leaders need to say what they're going to do and do it themselves first. They can't just tell other people to do something when they don't do it themselves. If they tell people to be thrifty, honest, righteous, fair, and impartial, but they themselves are lazy, don't do what they're supposed to, live lavishly and wastefully while most people's lives are still very poor, and always find ways to steal money from the State and the people, that's unacceptable (Nguyen, 2016). Uncle Ho, in and of himself, has always been a brilliant illustration of the virtues of leading a life that is simple and incorruptible. A great number of politicians from other countries have expressed their astonishment at the lifestyle of national leaders like Uncle Ho. The supper that Uncle Ho prepared consisted of the same few vegetables, eggplant, and soy sauce that the average person would eat. Uncle Ho lived in the house on stilts, dressing in old garments and donning a pair of rubber sandals made from old tires. He wore these

## **The Uniqueness of Ho Chi Minh in Political Communication**

sandals everywhere he went, including on outings to visit people in other communities, throughout his daily life, and even on trips to other countries. Uncle Ho was offered a new pair of shoes by the people, but he refused to receive it because the Vietnamese people were still impoverished and had a pressing need to save their resources. Uncle Ho was known to make unannounced and unplanned trips on occasion so that he could learn the truth about the community firsthand. Uncle Ho would not mind traveling to many regions to learn about the lives of people and to listen to their hopes and dreams in order to find solutions to make people's lives better and more successful. The things that Uncle Ho said were never separated from the things that he did, and Uncle Ho was always the one who did things first. As a result, the people listened attentively to everything Uncle Ho said and responded appropriately to it.

In addition, we can see that the majority of world's politicians have one thing in common, and that is the fact that they are under constant pressure to maintain a presentable image, despite the fact that people think politicians are unreachable. Others make a concerted effort to cultivate the impression that they are well-connected to the community in order to win over their sympathies and secure widespread support. For instance, during a speech that President George W. Bush gave about employment, those sitting directly behind the president were asked to remove their ties so that Mr. Bush would appear on television as "a leader of the people." (Shella, 2003). It would appear that voters have a preference for leaders who keep their platforms straightforward and accessible. This point is best shown by the former U.S. President, Barack Obama. In contrast to most other politicians, Barack Obama consistently engages in very straightforward behavior and uses straightforward language, both of which serve to pique the curiosity of the American people and earn their affection. People not only in the United States but also in other countries have expressed a lot of surprise and delight when seeing a powerful president also eat popular dishes, for example, when he stopped by Five Guys to buy a cheeseburger, he also bought a few more for the employees in his office (Herbert, 2009). They loved him even more when they realized that he cared about his subordinates by purchasing additional meals for them. This showed that he was compassionate. These various images and accounts of President Obama quickly became widespread in the media, which produced a highly favorable influence in the minds and hearts of the general public, ultimately leading to an increase in support for him.

But with President Ho Chi Minh, all of these things do not need to be built up; rather, they occur naturally every day because they come from his own personality, there is no need for any arrangement, and he does not need anyone to acknowledge them because everything he does is for the people and he never thinks about himself. It would appear that there is no space separating the common people and their leader when he was present, which is a significant achievement. Not only did Uncle Ho eat rustic food on occasion, and not only did he care about the people in his immediate vicinity, but he cared about the entire population. These were the kinds of things that take place on a regular basis. As was noted earlier, Uncle Ho did not eat differently, dress differently, or sleep in a different location from other people. Uncle Ho's diet consisted of the same things that other commoners did, such as salted eggplant, braised fish, and soy sauce. The rubber sandals constructed from tires that Uncle Ho wore through the combat zone and into the capital city were the same sandals that he continued to wear for the rest of his life. Uncle Ho's house was built on stilts, and he always wore old clothing. He was concerned about the well-being of all those who were close to him. Uncle Ho refused to accept the material items that people had prepared for him as well as the benefits that came with being the leader. For instance, when Uncle Ho traveled to India, the security team attempted to conceal Uncle Ho's slippers and replace them with a new pair while he was traveling on the airplane. After the plane had landed, Uncle Ho tried to hunt for his slippers but was unsuccessful. Others said that perhaps he had accidentally mixed them up with his other belongings in the luggage compartment and suggested that he use the new shoes in the interim. But Uncle Ho responded, "I am aware that you put away my slippers. Our nation is not yet fully independent, our people are still having a hard time, I wear rubber sandals but there is a new pair of socks inside, that is enough and it will still be polite." (Le, 2021). All of these things give the impression of a leader who is approachable and unpretentious, who maintains zero distance from the general populace, and who is solely concerned with the welfare of the populace while ignoring his own needs. At this stage, there were not nearly as many positive and significant stories being published about him in the mainstream media as there are now with politicians. Since Uncle Ho's way of life and the people in it are genuine, there is no need to construct a persona for others to be aware of in order to boost his own personal status. However, the deeds of President Ho Chi Minh and the moral example he set are constantly recounted to one another. As a result of this, it shouldn't come as much of a surprise to learn that many Vietnamese people think of Uncle Ho as a relative in their own families. And so, the things that Uncle Ho said, they all very respectfully listened to him and followed because they believed in him and believed that those ways were true for them, for a better life for themselves.

### **C. He is always proactive in listening to and understanding people's wishes**

As mentioned above about bottom-up direction, Pippa Noris and Brian McNair suggested that is when people tell those in power what they think so they can change policies and political activities to better meet people's needs. In the present time, people can do this in many different ways, such as by taking part in forums, giving interviews to the media, writing articles, blogging, and through reframing. But when President Ho Chi Minh was in power, information technology wasn't that advanced, and people didn't have as many ways to express what they thought as they do today. Also, after the August Revolution in 1945 was successful, the Democratic

## The Uniqueness of Ho Chi Minh in Political Communication

Republic of Vietnam was born with a lot of problems, such as hunger and illiteracy. 95% of the population was illiterate and unable to write (Pham, 2006). Therefore, it was difficult to make people comprehend the policy direction that the Party and the State were heading in, and it was impossible to discuss whether or not they are allowed to voice their opinions. Understanding this, President Ho Chi Minh on the one hand approved short slogans and articles with easy-to-understand language as mentioned above to make it possible for the general public to understand the content being transmitted; on the other hand, the President always actively created conditions for people to express their opinions by always visiting and directly chatting to communicate and to listen and understand the thoughts and aspirations of the people, as Uncle Ho asserted in his work titled "Dân vận" ("Mass mobilization"), "...anything must be discussed with the people, consulted and experienced by the people, put together a plan together with the people to be practical with local, and then the whole people must be mobilized and organized to put the plan into action." (Hồ Chí Minh toàn tập, ep.6).

Uncle Ho went on a secret trip on New Year's Eve 1946, just a few months after he announced the declaration of independence that started the Democratic Republic of Vietnam, which is now called the Socialist Republic of Vietnam. On New Year's Eve, when all of the other villagers in the village were lavishly organized to make offerings, he saw a family of cycling cyclos; in their house, there was nothing but a burning incense stick, and the owner was laying sick. Uncle Ho broke down in tears and asked to report to the President of Hanoi. These travels in disguise went happening on a regular basis. In 1960, on New Year's Eve, Uncle Ho traveled to Hanoi and paid a visit to one of the most impoverished households in the city at that time. Uncle Ho noticed that the owner was a lady in her forties who was still working as a freelance water carrier so that she might earn enough money the following morning to purchase some rice for her four children, all of whom were having a hard time at home. The sole furnishings in her home were a bed and a couple of chairs made of wood. Uncle Ho listened to her explanation about her predicament and then asked her if she intended to look for work. After that, a position that was appropriate for this woman was found for her. Because he wanted to see with his own eyes the truth about the lives of the people, grasp the genuine conditions of the people, and listen to the people's talk, these incognito journeys were never announced in advance. He knew that if he let the local leaders take care of it, he would only get to see the good parts of the area and meet people who were living full, happy lives. Also, after what happened in the spring of 1960, when he left, he said that the government was not really by the people and for the people because it let so many people have hard lives and because leaders were still bureaucratic, chasing achievements, and not going deep into people's lives, so serving the people was not good. After that, Uncle Ho was very harsh in his criticism of cadres and Party members who had not carried out their responsibilities effectively or had degraded themselves (Tran, 2016).

Or, when Uncle Ho visited farmers, he conversed and worked directly with them. Uncle Ho revised his will in 1968 after personally observing the difficulties and hardships endured by farmers and comprehending their desires and added that during many years of wars, "...our compatriots, especially peasants, have always been very loyal to our Party and Government, doing their best to contribute people, and willingly enduring all difficulties and hardships. Now that we have entirely won, I aim to propose a one-year agricultural tax exemption for agricultural cooperatives in order to make the people happy, and more enthused and to increase output." (Hanoimoi, 2014).

Consequently, during the time of President Ho Chi Minh, even though people did not have as many means to actively voice their opinions as they do today, Uncle Ho always created conditions to approach people directly in order to listen to their hopes and learn about their living conditions. Then, he made necessary modifications with the leadership team while simultaneously promoting economic growth to improve the living standards of the populace.

It is possible to assert that in the political communication activities of President Ho Chi Minh, there are similarities with the theories of other international authors; nonetheless, it is distinct in that it bears its own unique imprint from Uncle Ho's personality.

## IV. DISCUSSION AND CONCLUSION:

The methods of political communication that President Ho Chi Minh used were extraordinarily progressive, and as a result, he achieved a high level of popular consensus. In the direction from the government down to the people, known as the top-down direction, Uncle Ho has always placed a significant amount of emphasis on the work of "Dân vận" ("Mass mobilization"). This refers to the act of communicating and educating the populace about the activities of the state, with the goal of encouraging people to carry out the responsibilities that have been delegated to them by the state and various mass organizations. In this regard, Uncle Ho always emphasized the need of letting people understand since he knew that when people did, they were more likely to believe it and follow voluntarily. To help people understand, the Government needs to learn how to talk properly and uses language that are simple and easy to comprehend. When a piece of material is being disseminated, it needs to be clear, succinct, and appropriate to the circumstances and qualifications of the individuals so that it can be understood by everyone, from highly educated people to farmers. Also, he always stressed that "saying and doing must go hand in hand.". When he said something, he did it himself first. Therefore, he successfully gained the trust from his people. Uncle Ho always lived in a simple style and cared a lot about how other people lived. We can see the image of a leader who can

## The Uniqueness of Ho Chi Minh in Political Communication

fully blend in with the people in him. As a result, the people adore Uncle just as much as they do with their own family members. These things that emerge naturally from President Ho Chi Minh's personality, and they do not need to be constructed or arranged in the same way that many other politicians in this modern day do with a lot of supports from technical media.

When it comes to the bottom-up direction, this refers to the way in which individuals have the ability to voice their thoughts to the government in order for the latter to make the essential adjustments required to establish policies that are more suitable for the lives of individuals. During the time of President Ho Chi Minh, even though Vietnamese people did not have as many means to express their opinions and desires as people do nowadays, Uncle Ho was the one who deliberately established conditions for them to show their desires. Uncle Ho often went to localities, production places, agencies, factories, and schools, where he met people from all walks of life and listened to their hopes, opinions, and to see the living condition of people by himself. He did this instead of relying on what the leaders of these places told him, so he could remind the staff and make policies that pleased the people and made their lives better.

In conclusion, the strategies of political communication that President Ho Chi Minh utilized were extremely innovative, very effective, and contributed to the formation of a societal consensus. These approaches are similar to the theory that was advanced by international researchers during the later period; nevertheless, it also reveals numerous differences, marking their unique imprint on Uncle Ho's personality. It is possible to assert that the strategies of political communication that were utilized by President Ho Chi Minh are still relevant and valuable in the present day.

## REFERENCES

- 1) Chaffee, S.H. (1975), *Political Communication*. Sage Publications, Beverly Hills, CA, p.15.
- 2) Crick, Bernard (2004). "Politics as a Form of Rule: Politics, Citizenship and Democracy." What is Politics, edited by Adrian Leftwich, p.67.
- 3) Hanoimoi (2014), "'Absolutely Secret' – Uncle Ho's Will Edited in 1968", New Hanoi News, <http://www.hanoimoi.com.vn/tin-tuc/Chinh-tri/700300/tuyet-doi-bi-mat--ban-di-chuc-bac-sua-chua-nam-1968>, retrieved on Jun 02, 2022.
- 4) Herbert, Gerald (2009), "Obama Makes Another Cheeseburger Run", NBC News, <https://www.nbcnews.com/id/wbna31002348>, retrieved on Mar 09, 2022.
- 5) Hồ Chí Minh (2011). *Toàn tập*. Hanoi: National Political Publishing House, ep.6. p 233
- 6) Hồ Chí Minh (2011). *Toàn tập*. Hanoi: National Political Publishing House, ep.2. p 283-284.
- 7) Hồ Chí Minh (2011). *Toàn tập*. Hanoi: National Political Publishing House, ep.1. p. 284.
- 8) Huy Hung (2021), "Uncle Ho with the Vietnamese Revolutionary Press: The One Who Gave Birth and Set the Fundament for the Vietnamese Revolutionary Press.", Vietnamese Fatherland Front Journal, the Central Committee of the Vietnamese Fatherland Front, <http://tapchimatran.vn/nhan-vat/bac-ho-voi-bao-chi-cach-mang-viet-nam-nguoi-khai-sinh-va-dat-nen-mong-cho-bao-chi-cach-mang-viet-nam-39769.html>, retrieved on Aug 05, 2022.
- 9) Le, Quang X. (2021), "Learning Uncle Ho's Simplicity through the Story 'Uncle Ho's Sandals'", Supreme People's Procuracy in Gia Lai of Vietnam, <https://vksnd.gialai.gov.vn/Hoc-tap-lam-theo-loi-Bac/hoc-tap-duc-tinh-gian-di-cua-bac-qua-mau-chuyen-doi-dep-bac-ho-1612.html>, retrieved on Jun 18, 2022.
- 10) McNair, Brian (2011), *An Introduction to Political Communication*. Routledge, New York, NY, p.4.
- 11) Naciscione, Anita (2001), "Phraseological Units in Discourse: Towards Applied Stylistics", Riga: Latvian Academy of Culture.
- 12) Nguyen Binh (2016), "Ho Chi Minh's Style: Talk the Talk, Walk the Walk", Central Committee of the Communist Party of Vietnam, <http://dukqctw.dcs.vn/phong-cach-ho-chi-minh-noi-di-doi-voi-lam-SDEG-duk3498.aspx>, retrieved on Aug 16, 2022.
- 13) Nguyen, Toan V. (2020), "Uncle Ho's Style of Writing for Newspaper and His Story When Naming a Newspaper of Hanoi", Nghe An News, <https://baonghean.vn/cach-viet-bao-cua-bac-ho-va-chuyen-nguoi-dat-ten-cho-mot-to-bao-cua-ha-noi-269041.html>, retrieved on Jul 05, 2022.
- 14) Norris, Pippa (2015), "Political Communication". International Encyclopedia of the Social & Behavioral Sciences, edited by James D. Wright. Elsevier, pp. 342-349.
- 15) Pham, Yen H. (2006), "President Ho Chi Minh With the Popular Education Movement", Quang Binh Department of Education and Training, <https://sgddt.quangbinh.gov.vn/3cms/chu-tich-ho-chi-minh-voi-phong-trao-binh-dan-hoc-vu.htm>, retrieved on Jul 05, 2022.
- 16) Ha, Phuong H. (2021), "Learn Uncle Ho's Style in Doing Professional Journalism", People's Army Newspaper, <https://www.qdnd.vn/van-hoa/doi-song/hoc-bac-ho-lam-bao-chuyen-nghiep-662654>, retrieved on Jul 09, 2022.
- 17) Rozina, Gunta and Karapetjana, Indra (2009), "The Use of Language in Political Rhetoric: Linguistic Manipulation", academia.edu,

## The Uniqueness of Ho Chi Minh in Political Communication

[https://www.academia.edu/26225075/SD%C3%9C\\_Fen\\_Edebiyat\\_Fak%C3%BCltesi\\_The\\_Use\\_of\\_Language\\_in\\_Political\\_Rhetoric\\_Linguistic\\_Manipulation](https://www.academia.edu/26225075/SD%C3%9C_Fen_Edebiyat_Fak%C3%BCltesi_The_Use_of_Language_in_Political_Rhetoric_Linguistic_Manipulation), retrieved on Mar 03, 2022.

- 18) Shannon, Claude E., and Warren Weaver (1949). *A Mathematical Theory of Communication*. University of Illinois Press, Chicago, p. 3.
- 19) Shella, J. (2003). “Some Audience Members Told Not To Wear Ties for Bush Speech”, WISH-TV 8. <http://www.wishtv.com/global/story.asp?S1278487>, retrieved on Feb 22, 2022
- 20) Swaim, Barton (2015), “How Donald Trump’s Language Works for Him.”, Washington Post, <https://www.washingtonpost.com/news/the-fix/wp/2015/09/15/how-trump-speak-has-pushed-the-donald-into-first-place/>, retrieved on Mar 06, 2022.
- 21) Tran, Q. Nhiep (2016), “Uncle Ho Takes Care of Everyone When New Year Comes.”, Ca Mau Province Portal <https://www.camau.gov.vn/wps/portal/trangchitiet/!ut/p/z1/vVRdb5swFP01e> , retrieved on Sep 03, 2022.



There is an Open Access article, distributed under the term of the Creative Commons Attribution – Non Commercial 4.0 International (CC BY-NC 4.0)

(<https://creativecommons.org/licenses/by-nc/4.0/>), which permits remixing, adapting and building upon the work for non-commercial use, provided the original work is properly cited.